

EXHIBIT PROSPECTUS



NATMEC

www.NATMEC.org

Improving Traffic Data Collection, Analysis, and Use

Held in Conjunction with the

International Conference on Weigh-in Motion (ICWIM)

<http://iswim.free.fr/icwim6>

June 4–7, 2012

**The Fairmont Dallas
Dallas, Texas**



TRANSPORTATION RESEARCH BOARD

OF THE NATIONAL ACADEMIES

Why Exhibit?

The North American Travel Monitoring Exposition and Conference (NATMEC) is the premier venue where state and MPO traffic data collectors, traffic data users, and managers of data programs come together to keep abreast of new products and services.

This biennial specialty conference is for equipment manufacturers, software developers, and service providers to meet with current and potential customers. Exhibiting at NATMEC offers a targeted audience for marketing your products and services.

In addition, the 6th International Conference on Weigh-in-Motion (ICWIM6) is being held in conjunction with NATMEC. This conference is designed to address a broad range of technical issues related to weighing vehicles in motion, including providing access to the latest research and emerging technologies, analysis, and application of the WIM data for improving transportation systems. An increased attendance at NATMEC is anticipated to provide an international audience.

The exhibits open with a two-hour reception on Monday. Lunch and refreshment breaks are offered in the exhibit hall on Tuesday and Wednesday. These session-free times and exhibit-hall poster sessions are designed to enhance booth traffic in an informal and festive setting for visiting with prospective customers.

Reach the traffic data world by exhibiting at NATMEC!

2012 Schedule at a Glance

	Monday June 4	Tuesday June 5	Wednesday June 6	Thursday June 7
7:00 a.m.				
8:00 a.m.				
9:00 a.m.		Plenary Session	Breakout Sessions	Breakout Sessions
10:00 a.m.		Break	Break	Break
11:00 a.m.		Breakout Sessions	Breakout Sessions	Closing Session
Noon				
1:00 p.m.		Lunch in Exhibit Hall	Lunch in Exhibit Hall	
2:00 p.m.		Breakout Sessions	Breakout Sessions	
3:00 p.m.		Break	Break	
4:00 p.m.		Breakout Sessions	Breakout Sessions	
5:00 p.m.				
6:00 p.m.	Reception and Exhibit Opening			
7:00 p.m.				

2010 Profile of Attendance

EMPLOYER	NUMBER OF ATTENDEES
State or Province	87
MPO–Local	27
Federal	26
University	56
Private	52
International	15
Other	16
TOTAL	279

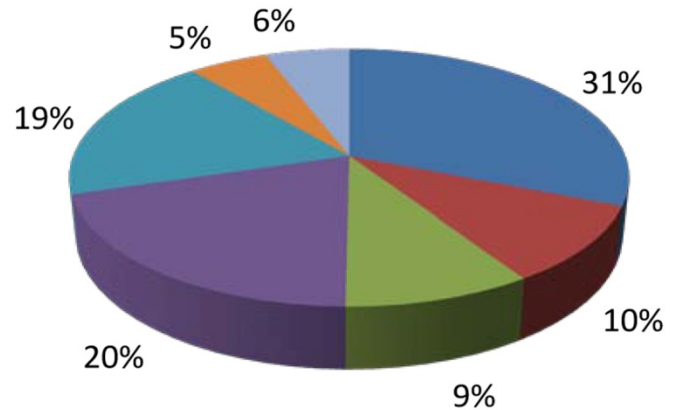

2010 Exhibitors

Advanced Traffic Products
 CA Traffic LTD
 CASE Global Technologies
 Chaparral Systems Corp.
 Diamond Traffic Products
 Digital Traffic Systems, Inc.
 ECM Inc.
 Eco-counter
 Econolite
 Federal Signal Technologies
 FHWA
 Global Traffic Technologies
 Image Sensing Systems Canada
 International Road Dynamics Inc.
 JAMAR Technologies, Inc.

Kistler Instrument Corp.
 Measurement Specialties Inc.
 MetroCount USA, Inc.
 Miovision Technologies
 MS2
 OpticLanes
 Peek Traffic Corporation
 PTV America, Inc.
 Sensys Networks
 Southern Traffic Services, Inc.
 TDC Systems
 The Traffic Group, Inc.
 TimeMark Incorporated
 Transmetric America Inc.

Exhibit General Information

VENUE

The Fairmont Hotel
Dallas, Texas

Exhibit Dates: June 4–6, 2012
Exhibit Hall: Regency Ballroom

SPACE RENTAL FEE & TERMS

Fees are per 10' x 10'. **Full payment by credit card is required at time of online application.**

- \$1,950 on or before December 1, 2011
- \$2,750 after December 1, 2011

Refunds will be issued for written cancellations and/or reductions in space as follows:

- Full refund until December 1
- 50% refund, December 2–March 1
- No refunds after March 1

SPACE ASSIGNMENT & ONLINE RESERVATION

[Apply for Space](#)

Assignments will be made on a first-come, first-served basis. In-line booths may be combined to create a larger in-line booth; **corner booths may not be combined**. See floor plan on Page 8.

Your space rental fee includes a listing in the *NATMEC Final Program* and two complimentary exhibitor badges per 10'x10' booth that allow admittance to conference sessions. Visit www.NATMEC.org to register additional booth personnel at the special rate of \$300. Badges may be picked up onsite beginning Monday at 8:00am.

[Apply for your booth online](#); for hotel and transportation information, visit www.NATMEC.org. Required at the time of registration:

- Payment, by American Express, MasterCard, or VISA (Federal Identification 53-0196932)
- *Final Program* description (50-word maximum)
- Names for two complimentary exhibitor badges per 10' x 10' (includes conference sessions)

EXHIBIT HALL HOURS

Monday, June 4, 5:30 p.m.–7:30p.m.

Opening Reception

Tuesday, June 5, 10:00 a.m.–4:00 p.m.

Morning Break, 10:00 a.m.–10:30 a.m.

Lunch, Noon–2:00 p.m.

Afternoon Break, 3:30 p.m.–4:00 p.m.

Wednesday, June 6, 10:00 a.m.–2:00 p.m.

Morning Break, 10:00 a.m.–10:30 a.m.

Lunch, Noon–2:00 p.m.

Exhibit General Information (continued)

EXHIBITOR GUEST PASSES

Exhibitor Guest Passes (25 per 10' x 10' booth) will be electronically distributed to each exhibiting company. These will be valid Tuesday afternoon from 2:00 p.m.–4:00 p.m.

Exhibitor Guest Badges are for

- Anyone interested in purchasing your products and services;
- Spouses of your employees; and
- Distributors or sales representatives who do not work for your company.

Exhibitor Guest Badges are *not* for contractors or service technicians involved in your exhibit set up.

SERVICE KIT

Each 10' x 10' booth will be set with one 7" x 44" one-line identification sign imprinted with company name and booth number; 8' high back drape; and 36" high side drape. Overnight perimeter security will be provided from installation through dismantle or until all freight has been removed.

Freeman is the official general service contractor and will supply the online *Exhibitor Service Kit* in early May. Services include but are not limited to exhibit furniture, cleaning, electrical, telephone, and Internet. 2011 Sample Pricing follows:

- Booth Package Specially Priced @ \$113.48 (includes 6' draped table, side chair, and wastebasket)
- 6' draped table @ \$101
- Side chair @ \$44
- Wastebasket @ \$17
- Standard Electrical Outlet @ \$85
- Internet \$400 (3 day service)

INSTALLATION & DISMANTLE (PRELIMINARY)

Installation: Monday, June 4, 8:00 a.m.–5:00 p.m.

Dismantle: Wednesday, June 6, 2:00 p.m.–10:00 p.m.

Exhibitors will have access to the exhibit hall on Monday, June 4, from 8:00 a.m. until 5:00 p.m. All booths must be installed and ready for the Opening Reception by 5:00 p.m. Any booth not occupied by 1:00 p.m. is subject to forfeiture with no refund of booth or registration fees.

Exhibitors may access the exhibit hall 1 hour prior to opening and remain 30 minutes after the close each day. All booths must be staffed during open hours.

No booth may be dismantled, nor may packing start, before 2:00 p.m., Wednesday, June 6. All booth material must be crated and ready for removal by 6:00 p.m. on Wednesday. It is the exhibitor's responsibility to pack and remove or consign for shipment all items of value prior to leaving booth unattended. Any materials remaining after 6:00 p.m. that are not consigned to a specific carrier will be shipped by the official carrier at the exhibitor's expense.

Exhibit General Information (continued)

DISPLAY SIZES & LIMITATIONS

In-line Booths

A Standard Booth is one (10' x 10') or two booths (10' x 20') in a straight line. Peninsula booths are not allowed. Exhibit fixtures, components, and identification signs will be permitted to a maximum height of 8' in the back 5' of the booth. No solid exhibit construction or freestanding display fixtures over the height of 4' are allowed in the front 5' of the exhibit.

Structures (other than literature tables or counters) designed for holding computers, monitors, televisions, video screens, or similar display elements, signs, etc., must not be placed in the front 5' of the exhibit booth. Materials, equipment, and floral presentations in the front 5' of the display that exceed 4' from the ground must not create an obstruction that prevents clear view of neighboring exhibits. The rule of thumb is to stand at one end of an aisle and have a clear view of the space above 4' in the front 5' of all booths in that aisle.

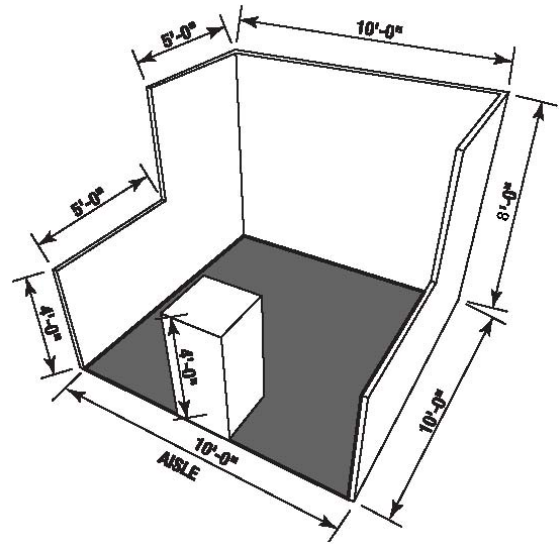

Perimeter Wall Booths

Booths along the perimeter of the exhibit hall must conform to the 8' height limitation.

End of Aisle

Exhibitors with a booth at the end of the aisle may not open their booth to traffic on two sides of the booth.

Height Restriction

An in-line exhibit booth may not exceed the height of 8' from the exhibit hall floor; island booths may be permitted to exceed the 8' height restriction with prior written approval from TRB.

SHIPPING

All shipments must be **prepaid** and a copy of the bill of lading forwarded to Freeman. Complete shipping instructions will be included in the *Exhibitor Service Kit*.

Warehouse Shipments: The deadline for shipping to the warehouse is Tuesday, May 29. After this date, a late fee may apply.

Exhibiting Company Name/Booth # _____
NATMEC 2012
c/o Freeman
5130 Cash Road
Dallas, TX 75247

No Show-site Shipments. The Fairmont Dallas Hotel is not equipped to accept freight. Freight must be sent in advance to the Freeman warehouse and **not directly to the hotel**. For questions, please contact Freeman at 214-634-1463.

Exhibitor Advisory Council

Members

LJ Wilkinson
Chaparral Systems Corporation
LJ@ChapSys.com

Ronald White
North American Operations
Electronique Controle Mesure (ECM)
Ron@ECMUSA.com

Steve Perone
PTV America, Inc.
SPerone@ptvamerica.com

Renata M. Haberkam
The Traffic Group
RHaberkam@TrafficGroup.com

Daniel Gossack
TimeMark, Inc.
DanielG@TimeMarkinc.com

Ex Officio
Catherine McGhee
Virginia Center for Transportation
Innovation and Research (VCTIR)
Cathy.McGhee@VDOT.Virginia.gov

Staff

Julie A. Miller
Transportation Research Board
of The National Academies
202-334-2362
JMiller@NAS.edu

Thomas M. Palmerlee
Transportation Research Board
of The National Academies
202-334-2907
TPalmerlee@NAS.edu

Contract Rules and Regulations

CONTRACT FOR SPACE

The *Exhibit Booth Application* and confirmation constitute a contract between the North American Travel Monitoring Exposition and Conference (hereinafter referred to as NATMEC) and the exhibitor. The following rules are part of the contract. Any point not specifically covered in these rules is subject to the decision of NATMEC, whose decision shall be final.

ELIGIBILITY FOR EXHIBITING

In keeping with the educational purposes of the conference, any exhibitor whose proposed exhibit will enhance the educational purpose of NATMEC is eligible to apply for space. NATMEC reserves the right to reject any application that in its judgment does not meet this criterion.

BOOTH ASSIGNMENTS

Assignments will be made on a first-come, first-served basis. In-line booths may be combined to create a larger in-line booth except that corner booths may not be combined. NATMEC reserves the right to reassign selected booth space with notification to exhibitor for the benefit of the exposition.

CANCELLATIONS

Exhibitor shall have the right to cancel this agreement at any time by written notice to NATMEC (online). Refunds will be issued for written cancellations and/or reductions in space as follows: full refund until December 1; 50% from December 2–March 1; no refunds after March 1. NATMEC retains the right to resell booth space canceled by the exhibitor.

EXHIBIT BOOTH

NATMEC will provide the following: a 10' x 10' standard booth, a 7" x 44" one-line identification sign listing company name and booth number, an 8'-high back drape and 36" side drape; carpeting (the hall is carpeted) and overnight perimeter security (beginning with setup and concluding after all freight has been removed).

Standard in-line booths may not exceed a back wall height of 8', and no part of the exhibit or equipment may exceed a height of 4' in the front half of the booth. All islands are restricted to a height of 10', including the identification sign. No exhibit is permitted to obstruct the view of adjacent booths. See *Display Sizes and Limitations*. NATMEC reserves the right to direct revisions, at exhibitor expense, of any exhibit that does not comply with these guidelines.

USE OF SPACE

No exhibitor is permitted to promote products, equipment, or services other than its own. If an article of a non-exhibiting firm or business is required for the operation or display of an exhibitor's wares, identification of such an article shall be limited to the usual and regular nameplates, imprinting, or trademarks under which article is sold in the regular course of business. No subletting or sharing of space is permitted. All activities must be confined to the limits of rented space and must not impede traffic or interfere with the activity of other exhibitors. NATMEC may evict exhibitors who, because of noise, conduct of personnel, methods of operation, or any other reason, detract from the general educational character of the meeting. In the event of eviction, NATMEC will not issue a refund. Order taking is permitted.

HOSPITALITY

Only companies with space contracted in the exhibit hall may use a suite for hospitality purposes. Hospitality suites may not be open during official program hours, which include social activities sponsored by NATMEC. Exhibitors are not permitted to display equipment or products or to conduct product demonstrations in suites or sleeping rooms during NATMEC.

DISTRIBUTION

Distribution of product/service literature may be made only within the booth space assigned to the exhibitor presenting such material. Firms or organizations not assigned space will not be permitted to solicit business at the conference. Only customary/descriptive product literature and samples may be distributed to meeting attendees. Contact the hotel if you would like to order food and beverage.

PROTECTION OF EXHIBIT FACILITY

Exhibitors shall not deface any part of the exhibit facility. The cost of repairing any damage caused by the exhibitor, its employees, representatives, or agents will be billed to and paid by the exhibitor. Nothing can be taped, tacked, nailed, screwed, or otherwise posted to the columns, walls, floors, ceiling, furniture or other property of the hotel. All setup and dismantling of exhibit booths and equipment must be conducted within the exhibit hall. No storage of exhibit materials will be permitted between or behind booth draping.

LABOR, SAFETY, & FIRE CODES

The exhibitor is responsible for knowledge of and compliance with all union requirements and fire and safety codes. Booth decorations must be flame-proofed and all hangings must clear the floor. Electrical wiring must conform with all federal, state, and municipal government requirements and to National Electrical Code Safety Rules. If inspection indicates that an exhibitor has neglected to comply with these regulations, or otherwise incurs fire hazards, the right is reserved to cancel at exhibitor's expense all or such part of the exhibit as may be irregular.

LIABILITY AND INSURANCE

The exhibitor is responsible for any claims arising out of its own negligence, or out of the negligence of its employees or agents. NATMEC will endeavor to protect exhibitor property through contracted security personnel on the exhibit hall perimeter.

The exhibitor shall be responsible for protecting its own property to its full value, either through purchased insurance or self-insurance. NATMEC will not assume responsibility for any loss or damage to exhibitor property.

In holding the Exhibit, NATMEC does not act as the agent of the exhibitor, the facility, the General Service Contractor, or any other party. Claims against any party other than NATMEC are to be submitted directly to the party involved.

In the event the Exhibit is canceled, or the exhibitor does not participate due to circumstances within the control of NATMEC, the liability of NATMEC shall be limited to a refund of all monies paid by the exhibitor as exhibit-booth rental and registration fees

[Apply for Space](#)

Preliminary Exhibit Hall Floor Plan

The Fairmont Dallas Regency Ballroom

